

5133

- Schnellspan-Bohrfutter
- Keyless drill chucks for industrial and CNC use

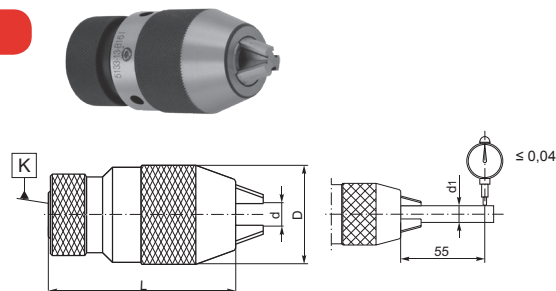

Rundlaufabweichung Max. concentr. error	Artikel Nr. Code No.	Rundlaufabweichung Max. concentr. error	Artikel Nr. Code No.	d max	K	Spannbereich Clamping range	D	L	d ₁
Präzision • precision		Standard • standard							
0,04	80000693	0,15	80000694	10	B12	0,5-10	43	84	6; 10
0,04	80000699	0,15	80000700	10	J2	0,5-10	43	84	6; 11
0,04	80000701	0,15	80000702	10	J33	0,5-10	43	84	6; 12
0,04	80000695	0,15	80000696	13	B12	1-13	50	95	6; 13
0,04	80000697	0,15	80000698	13	B16	1-13	50	95	6; 14
0,04	80000703	0,15	80000704	13	J2	1-13	50	95	6; 15
0,04	80000705	0,15	80000706	13	J6	1-13	50	95	6; 16
0,04	80000707	0,15	80000708	13	J33	1-13	50	95	6; 17
0,04	80000709	0,15	80000710	16	B16	3-16	58	103	6; 16
0,04	80000711	0,15	80000712	16	B18	3-16	58	109	6; 17
0,04	80000713	0,15	80000714	16	J6	3-16	58	103	6; 18
0,04	80000715	0,15	80000716	16	J3	3-16	58	109	6; 19

5361

- Kegel für Bohrfutter mit Aufnahme DIN 238
- Drill chuck mandrels for DIN 238 taper with tang

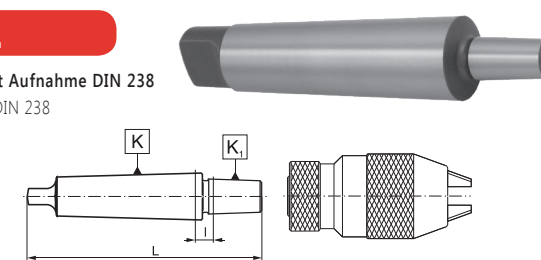

Artikel Nr. Code No.	K MK	K ₁ DIN	L	I	Artikel Nr. Code No.	K MK	K ₁ DIN	L	I
80000773	1	B10	86,0	6,0	800003437	3	B18V	132,0	11,0
80000774	1	B12	89,0	5,0	80000786	3	B22	147,0	17,5
80000775	1	B16	99,0	8,0	80000787	3	B24	157,0	17,5
80000776	1	B18	107,0	8,0	80000788	4	B12	152,5	13,0
800003435	1	B18V	97,0	8,0	80000789	4	B16	158,0	11,5
80000777	2	B10	105,0	12,0	80000790	4	B18	166,5	12,0
80000778	2	B12	106,0	9,0	800003438	4	B18V	159,0	14,5
80000779	2	B16	112,0	8,0	80000791	4	B22	176,0	13,0
80000780	2	B18	119,0	7,0	80000792	4	B24	186,0	13,0
800003436	2	B18V	108,5	6,5	80000793	5	B12	186,5	15,0
80000781	2	B22	130,0	9,5	80000794	5	B16	193,0	14,5
80000782	3	B10	121,0	9,0	80000795	5	B18	200,5	14,0
80000783	3	B12	127,0	11,0	800003439	5	B18V	191,0	14,5
80000784	3	B16	134,0	11,0	80000796	5	B22	208,5	13,5
80000785	3	B18	140,0	9,0	80000797	5	B24	221,0	16,0

5134

- Schnellspan-Bohrfutter
- Keyless drill chucks for industrial use

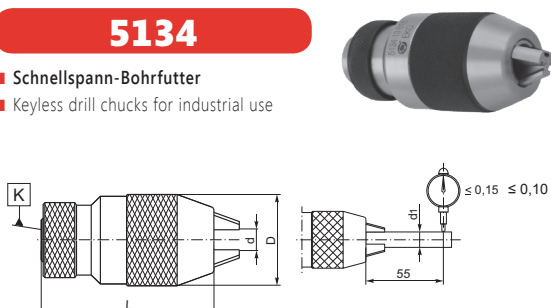

Artikel Nr. Code No.	d max	K	Spannbereich Clamping range	D	L	d ₁
800000720	10	B12	0,5-10	40	85,5	6; 10
800000721	10	B16	0,5-10	40	85,5	6; 10
800000722	10	½"-20	0,5-10	40	94,5	6; 10
800000723	13	B12	1-13	43	84,5	6; 13
800000724	13	B16	1-13	43	84,5	6; 13
800000725	13	3/8"-24	1-13	43	93,5	6; 13
800000726	13	1/2"-20	1-13	43	93,5	6; 13
800000727	16	B16	3-16	50	94,5	6; 16
800000728	16	B18	3-16	50	100,5	6; 16
800000729	16	1/2"-20	3-16	50	103,5	6; 16
800000730	16	5/8"-16	3-16	50	103,5	6; 16

5362

- Kegel für Bohrfutter mit Jacobs Aufnahme
- Drill chuck mandrels for Jacobs taper with tang

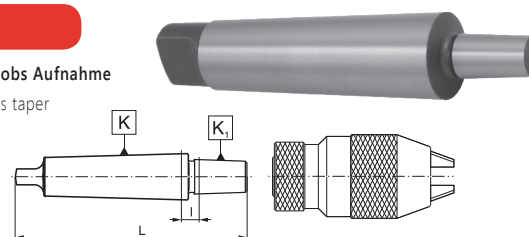

Artikel Nr. Code No.	K MK K MT	K ₁ Jacobs	L	I	Artikel Nr. Code No.	K MK K MT	K ₁ Jacobs	L	I
800000798	1	J0	80,5	7,4	800000813	3	J33	126,0	6,6
800000799	1	J1	83,8	5,1	800000814	3	J4	146,0	10,0
800000800	1	J2	90,5	6,3	800000815	3	J5	153,0	11,4
800000801	1	J3	100,5	7,5	800000816	3	J6	129,0	9,6
800000802	1	J33	95,0	7,6	800000818	4	J2	151,5	11,8
800000803	1	J6	95,0	7,6	800000819	4	J3	160,5	12,0
800000804	2	J0	95,5	9,5	800000820	4	J33	155,0	12,0
800000805	2	J1	102,5	9,8	800000821	4	J4	170,0	10,4
800000806	2	J2	106,0	8,8	800000822	4	J5	175,5	10,4
800000807	2	J3	112,5	6,5	800000823	4	J6	155,0	12,0
800000808	2	J33	107,0	6,6	800000824	5	J3	193,5	12,5
800000809	2	J4	128,5	11,4	800000825	5	J33	189,5	14,6
800000810	2	J6	107,0	6,6	800000826	5	J4	203,5	11,4
800000811	3	J1	120,5	9,8	800000827	5	J5	209,5	12,4
800000812	3	J3	131,5	6,5	800000828	5	J6	187,0	12,1

5363

- Kegel für Bohrfutter mit Aufnahme DIN 238
- Drill chuck mandrels for DIN 238 taper with drawbar thread

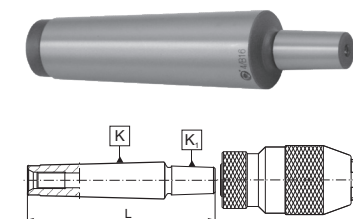

Artikel Nr. Code No.	K MK K MT	K ₁ DIN	L
800000829	2	B12	95
800000830	2	B16	101
800000831	3	B16	121
800000832	4	B16	143

1
2
3
4
5
6
7

5363
5362
5134
5361
5133