

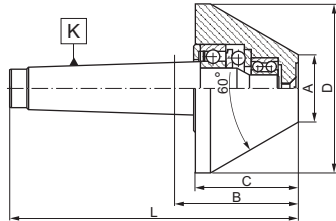

8825

- Mitlaufender Zentrierkegel 60°
- Truncated 60° point centres for holding tubular workpieces



Größe	K MK	Gewicht max.	U/min.	Rundlaufabweichung	Artikel Nr.	A	B	C	D	L
Size	K MT	Max. weight	RPM	Max. concentr. error	Code No.					
1	1	100	5000	0,008	800002598	20	40,5	35	50	94,0
2	2	180	5000	0,008	800002599	30	41,5	35	60	105,5
2-1	2	300	4500	0,008	800002600	30	59,0	53	80	123,0
3	3	350	4500	0,008	800002601	30	59,0	53	80	140,0
3-1	3	550	3000	0,008	800002602	40	67,0	61	100	148,0
3-2	3	600	3000	0,008	800002603	50	76,0	70	120	157,0
4	4	600	3000	0,008	800002604	40	68,5	61	100	171,0
4-1	4	700	3000	0,008	800002605	50	77,5	70	120	180,0
4-2	4	700	3000	0,010	800002606	70	77,5	70	140	180,0
5	5	750	3000	0,010	800002607	50	77,5	70	120	207,0
5-1	5	750	2000	0,020	800002608	100	77,5	70	170	207,0
6	6	2000	1000	0,050	800002609	180	116,0	107	292	298,0

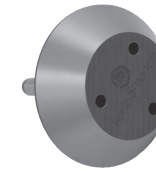

8882

- Mitlaufender Zentrierkegel 75°
- Truncated 75° point centres with interchangeable plates

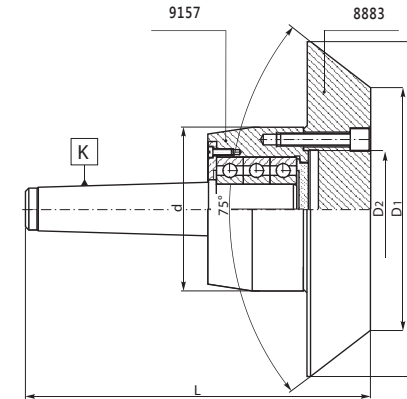

8410

- Hydraulik Stirnseitenmitnehmer
- Hydraulic face drivers

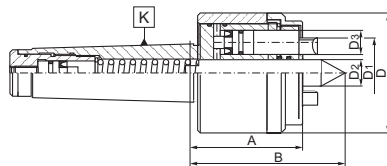

Artikel Nr.	D ₁	K MK	D	D ₂	D ₃	A	B	Rundlaufabweichung	Gewicht max.
Code No.		K MT						Max. concentr. error	Max. weight
800002740	27	4	68	12	12	64	80	0,02	55
800002741	27	5	68	12	12	64	80	0,02	55
800002742	40	4	81	14	12	67	84	0,02	65
800002743	40	5	81	14	12	67	84	0,02	65
800002744	50	5	90	20	18	86	113	0,03	100
800002745	63	5	100	20	18	86	113	0,03	100

K MK	d	D	D ₁	D ₂	L	Gewicht max.	U/min.	Rundlaufabweichung	Satz	Zentrierkegel	Grundkörper mitlaufend
									Set	Centering taper	Body rotating
Artikel Nr. • Code No.											
3	80	150	95	56	180	700	4000	0,05	800002954	800002967	800002984
3	80	200	145	56	180	700	4000	0,05	800002955	800002968	800002984
4	100	150	95	70	206	1000	3500	0,05	800002956	800002969	800002985
4	100	200	145	70	206	1000	3500	0,05	800002957	800002970	800002985
4	100	250	195	70	206	1000	3500	0,05	800002958	800002971	800002985
4	125	200	145	95	215	1500	3200	0,05	800002959	800002972	800002986
4	125	250	195	95	215	1500	3200	0,05	800002960	800002973	800002986
4	125	300	245	95	215	1500	3200	0,05	800002961	800002974	800002986
5	125	200	145	95	242	1500	3200	0,05	800002962	-	800002987
5	125	250	195	95	242	1500	3200	0,05	800002963	-	800002987
5	125	300	245	95	242	1500	3200	0,05	800002964	-	800002987
5	160	250	195	125	245	1800	3000	0,05	800002965	800002975	800002988
5	160	300	245	125	245	1800	3000	0,05	800002966	800002976	800002988

- 1
- 2
- 3
- 4
- 5
- 6
- 7

8410

8882

8825